

**SHRI GURU GOBIND SINGHJI**  
**INSTITUTE OF ENGINEERING & TECHNOLOGY, Vishnupuri, NANDED**

No. SGGSI&T/Store-3000/Brake Caliper/Mech./2021-22

Date: 24/11/2021

## Inquiry

**Subject: - Quotation for supply of Brake Caliper for Mechanical Engineering.**  
**[Specification attached Annexure – A & drawings (2 pages)]**

Dear Sir,

You are requested to send your most competitive quotation for the supply of above material, subject to Conditions mentioned. The quotation in sealed cover should reach this office on or before **02/12/2021** at 01=00 PM

The sealed cover should super scribe as QUOTATION for above material; Due on **02/12/2021** at **01:00 pm**. The quotation will be opened on **03/12/2021** At. 01:00 pm. If possible, in the presence of such suppliers who remain present.

### TERMS AND CONDITIONS:

1. Rates quoted are F.O.R. At Vishnupuri.
2. The taxes, Insurance, Freight, Packing & forwarding charges etc. If any must mention separately.
3. The validity period for the rates offered should be clearly mentioned and it should be 90 days from the date opening of the quotations.
4. The delivery period shall be clearly stated.
5. The item quoted should be confirm to the specification given please furnish your Details Specification against each item quoted. The relevant catalogue/pomp let should necessarily accompany the quotations.
6. The institution reserves the right to accept any quotation or reject any/all quotations and to order Any of the items in any quantity without assigning any reason
7. The items will have checked at the institute and acceptance is subject to the approval of the institute.
8. If the supply of any part thereof is rejected by institute the supplier will have to bear all expenses. Incurred in the matter including all charges for return and replacement of the items.
9. Guarantee should be minimum 12 months from demonstration/installation.
10. 100% payment will be made after receipt of material in good condition and approved by us.
11. If you are having with DGS&D rate contract, or your item is proprietary then please send copy of rate contract or proprietary item certificate along with authorized dealership certificate.
12. If your item/s is /are PROPRIETARY item, then you may please send the PROPRIETARY ITEM CERTIFICATE along with the quotation.
13. If you are AUTHORISED DEALER of any manufacturers, then please send the dealership Certificate and company price list along with the quotation.
14. **Penalty clause:** If supplier fails to supply the ordered material within the scheduled delivery period, for late delivery of goods we will entitled to recover the liquidated damages as a sum equal to ½ percent of the price of stores delivered late per week. As per store purchase manual Revised as per G.O (P) No.3/2013/SPD, dated 21.06.2013.

Thanking You,

  
DIRECTOR  
SGGS Institute of Engg. & Tech.  
Vishnupuri, Nanded.

## Annexure "A"

Custom Brake Caliper's Specifications: -

Number of units	:	1
Number of Pistons	:	2
Bore Diameter	:	28mm
Piston type	:	Stainless
Material	:	Al 7075 T6

6 5 4 3 2 1

D

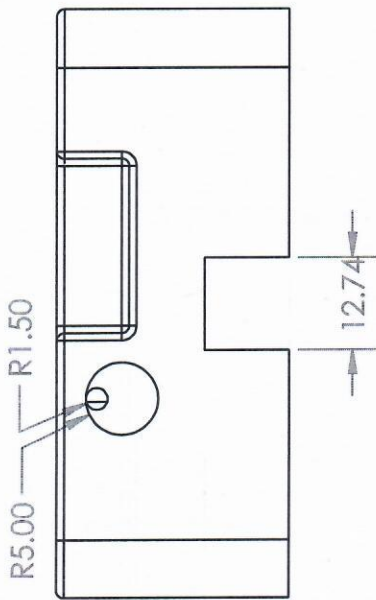

D

C

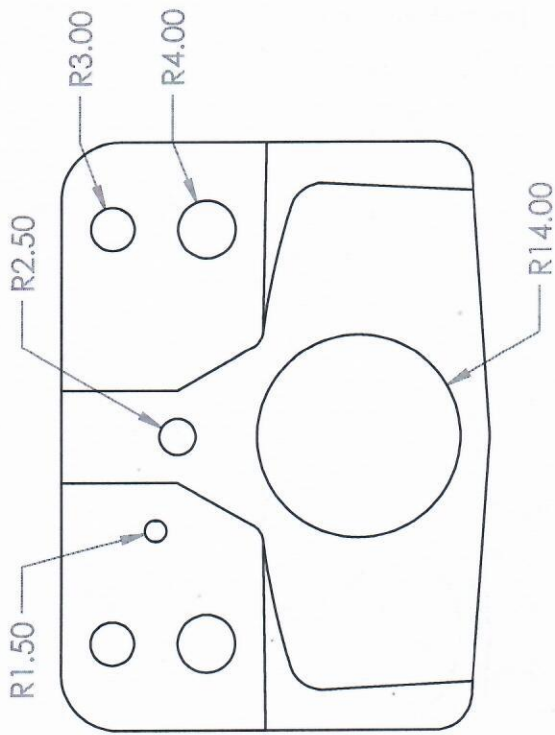

C

B

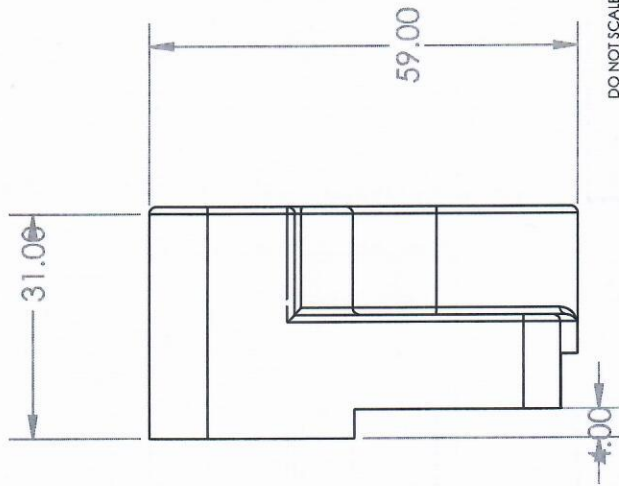

B

DO NOT SCALE DRAWING

REVISION

MATERIAL : AI 7075 T6

TITLE:

CALIPER SIDE 1

A

DWG NO.

001

A4

A

SCALE:1:1

SHEET 1 OF 1

6

6

5

4

3

2

1

6 5 4 3 2 1

D

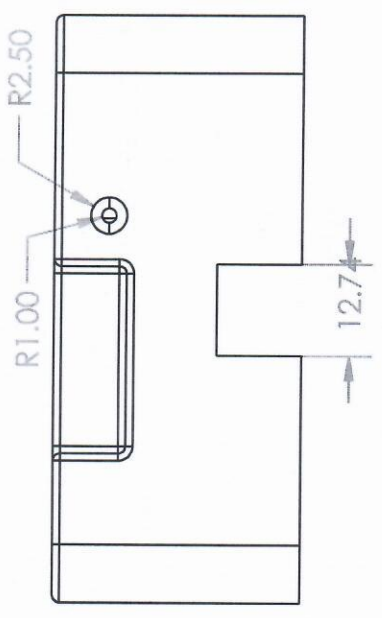

D

C

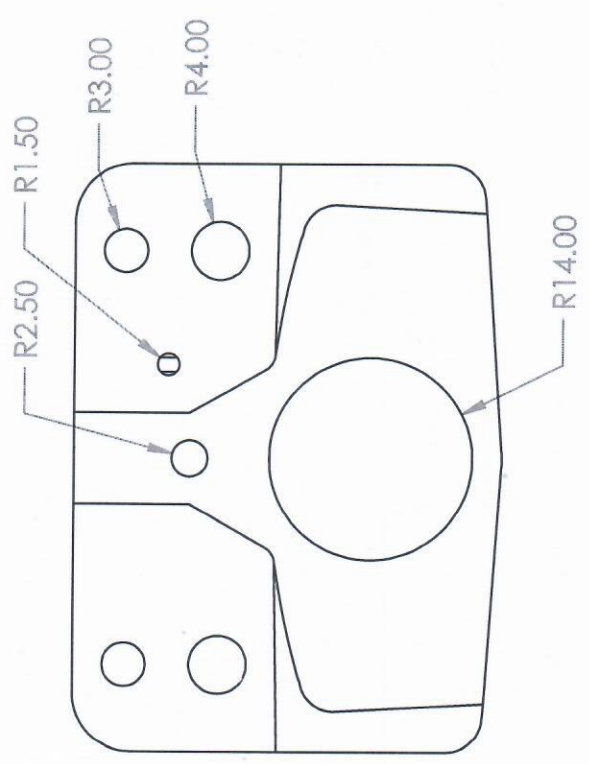

C

B

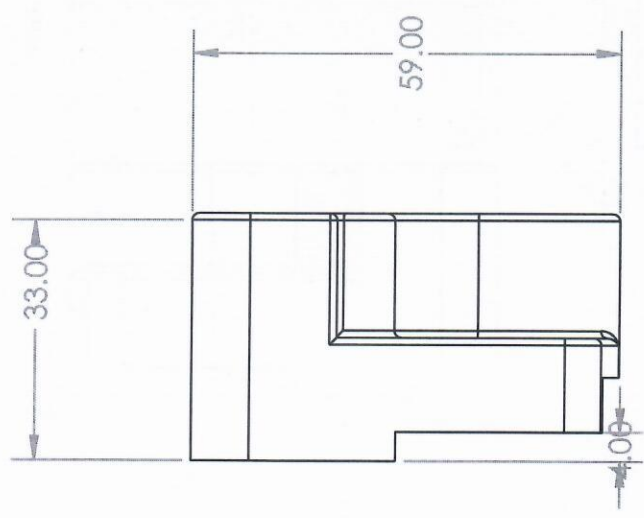

B

A

DO NOT SCALE DRAWING

REVISION

MATERIAL : AI 7075 T6

TITLE:

CALIPER SIDE 2

DWG NO.

002

A4

SCALE:1:1

SHEET 1 OF 1

6

5

4

3

2

1